

Classic Update Series

65 Ford Falcon

START HERE !

PLEASE READ THIS BEFORE STARTING INSTALLATION !

This wiring kit is designed for ease of installation. Please read the guidelines below, BEFORE STARTING your installation to guarantee a successful job. Use an appropriate crimping tool which folds the wings of the open barrel terminals down into the wire as shown below. ALL TERMINALS THAT YOU INSTALL SHOULD BE PROPERLY SOLDERED. Our factory crimped terminations are installed by GM approved five ton presses, and soldering these terminations is not necessary. AAW offers a great terminal crimping video entitled "Proper Crimping Video". It can be viewed by visiting YouTube. Type the following address into your web browser to go directly to the video: www.youtube.com/watch?v=8u_EkMsioMy.



PLEASE READ THESE HELPFUL INSTALLATION TIPS BEFORE GOING ANY FURTHER!

Prior to installing the Dash/Main harness in your vehicle, plug all of the fuses, flashers, (see a detailed photograph on page 12 of this instruction set) and Horn Relay into this harness.

AS THIS HARNESS IS DESIGNED FOR USE IN A MODIFIED VEHICLE REQUIRING A HIGHER RATE OF CHARGE, IT DOES NOT SUPPORT THE USE OF A STOCK (ORIGINAL) ALTERNATOR. IT IS DESIGNED FOR USE WITH AN INTERNALLY REGULATED GM "SI" STYLE OR SINGLE WIRE STYLE ALTERNATOR. ADAPTERS (WHICH ARE NOT INCLUDED WITH THIS KIT) THAT ARE AVAILABLE FROM SEVERAL SOURCES WILL BE NECESSARY TO USE ANY ALTERNATOR OTHER THAN A GM "SI" STYLE OR SINGLE WIRE STYLE UNIT.

STEP 1: DISCONNECT YOUR BATTERY:

Disconnect the battery before installing the wiring kit to prevent any accidental shorting caused by loose bare wire ends.

STEP 2: START INSTALLING KIT (see page 3):

This kit is broken down into individual steps that are identified by a letter printed on the instruction sheets visible through each bag. These letters are the order of operation for installing your kit. Start with bag letter G, then H, etc. The order of installation is shown below. Use this main instruction sheet, 92970579, to complete the installation process.

- G - 510380 Dash Harness Kit
- H - 510381 Gauge Cluster Kit
- M - 510383 Rear Body Kit
- N - 510382 Headlight Bucket Kit
- Z - 510476 Alternator and Main Power Connection Kit

STEP 3: RECONNECT YOUR BATTERY:

When you have completed the installation and are ready to reconnect the battery, make sure that the following electrical system grounds are in place:

- A. Battery is grounded to the ENGINE BLOCK.
- B. Battery is grounded to the frame.
- C. Engine block is grounded to the frame.
- D. Body is grounded to the frame.

STEP 4: CHECK ALL ELECTRICAL FUNCTIONS:

Any non-functioning items should be checked for proper installation. Any problems with your wiring and electrical circuit functions should be addressed to American Autowire Systems, Inc. as soon as possible to avoid any warranty problems.

If you have any questions concerning this or any of our products, please feel free to call us at 1-856-933-0801.

AMERICAN AUTOWIRE MAKES IT EASY !!

We carry many accessories for your 60-65 Ford Falcon

p/n 510585
OEM small terminal crimping
tool (18-14 gauge)



p/n 510586
OEM large terminal crimping
tool (12-8 gauge)

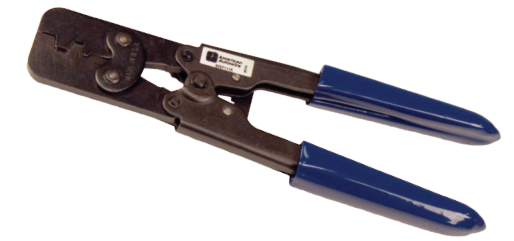

p/n 500918
Ford Duraspark Ignition Harness



p/n 500802
GM "SI" series to Ford "3G" int.
regulated alternator



www.americanautowire.com 856-933-0801

Classic Update Series

1965 Ford Falcon

510386

© COPYRIGHT 2004 American Autowire / Factory-Fit
Used with express permission of
American Autowire / Factory-Fit

92970579 Rev. 4.0 1/23/2018

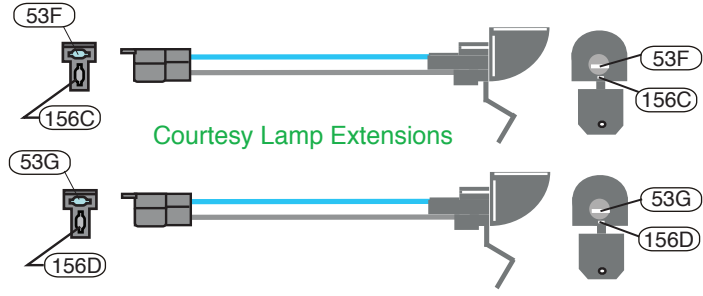
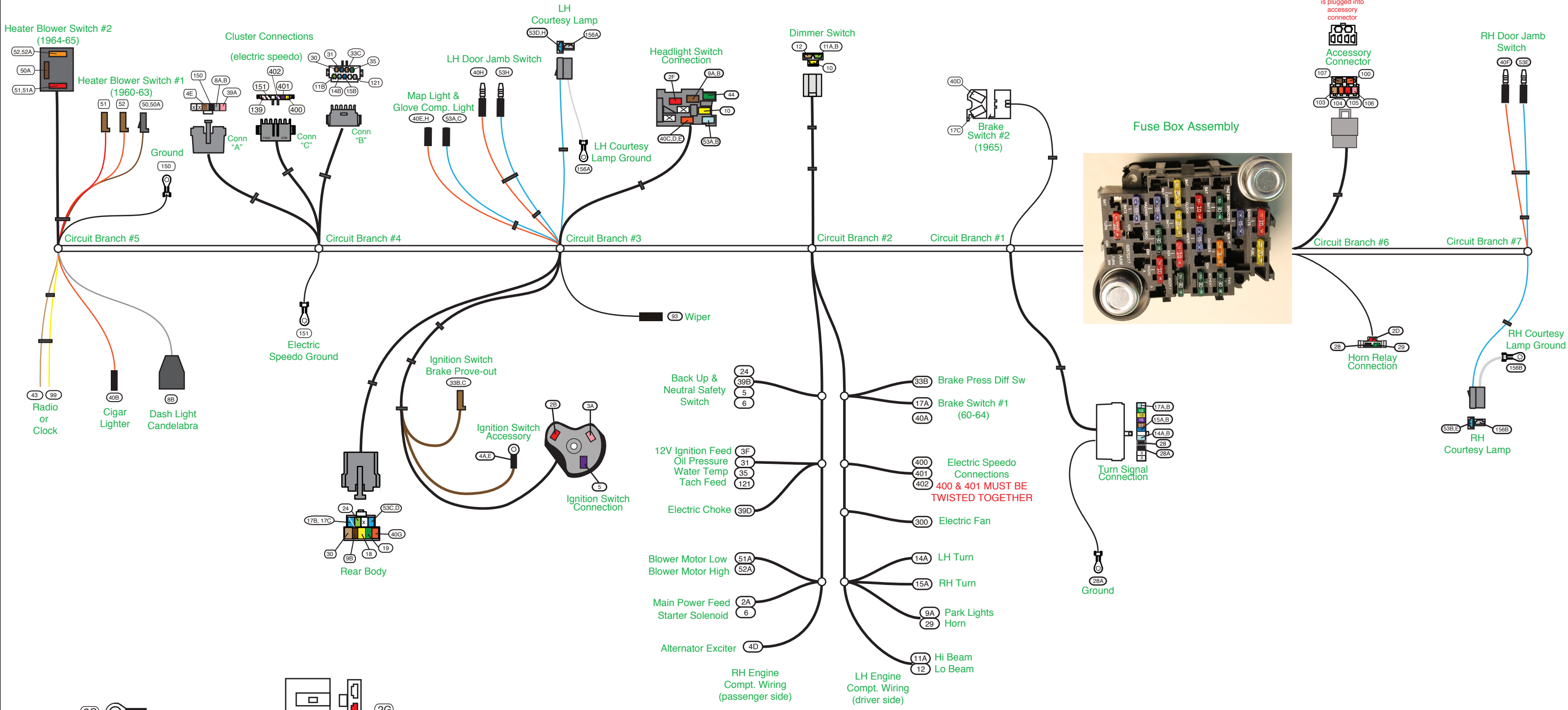

NOTE: Your new underdash courtesy lamp extensions use # 631 bulbs (not included with this kit). They may be purchased at any auto parts store.

PART # **510386**

DESCRIPTION:

1965 Ford Falcon

Classic Update Series Kit

92970579 Rev. 4.0 1/23/2018

Dash/Main Harness Installation Instructions

Obtain the Main Dash Harness 510380. Mount the Fuse Block first to the center of the Firewall per the Fuse Panel Mounting Instructions Template 92970595. Use the two #10 x 3" screws found in kit 510380 to mount the Fuse Block. Install the two round grommets G from kit 510384 in the original rectangular wiring pass through holes in the upper left corner of the Firewall. Route the Dash Wiring across the Wiper Motor Mounting Bracket and install clamp "S", with Bolt, Nut, and Washer "U" to the Wiper Bracket to hold the Dash Harness in place. Continue routing the Dash Harness across the Steering Column Support and attach the second clamp "S", with another Bolt, Nut, and Washer "U" to hold the Dash Harness in place. You will reuse the two original wraparound clips that are attached to the Steering Column Support Bracket (or Cluster) to hold the new Dash Harness in place as well as the original clip near the top left cowl area. Follow these instructions as well as the detailed drawings on pages 10 and 11. Now proceed to Circuit Branch 1 instructions.

Circuit Branch 1 - Underdash Connections

Turn Signal Switch Connector Plug into the Steering Column Turn Signal Switch connector. If you are using a stock Ford Steering Column on your vehicle, refer to Diagram 'A' and "Table A" – AAW Turn Signal Switch Wires to Stock Turn Signal Switch on page 9 for proper mating directions. This Dash Harness is designed to function with a GM style turn signal switch. Our connector mates to a 3 7/8 inch long plug used on 1969-1976 GM, IDIDIT, and many other aftermarket steering columns. Starting from 1977 on up, the GM switch changed and began using a 4 1/4 inch connector. That connector is from the same family and uses the same terminals. By using the supplied mating connector (L) and terminals (M) located in the loose piece kit bag G (see 510318 inside bag) it is easy to adapt any steering column to this Dash Harness. The different functions of the wires in the Dash Harness connectors are as follows:

Wire #	Wire Color	Printing	Description
14A	Light Blue	LEFT FRONT TURN	Feed to LH Front Turn Signal Lamp.
14B	Light Blue	LEFT DASH IND	Feed to Cluster Turn Signal Indicator Lamp.
15A	Dark Blue	RIGHT FRONT TURN	Feed to RH Front Turn Signal Lamp.
15B	Dark Blue	RIGHT DASH IND	Feed to Cluster Turn Signal Indicator Lamp.
16	Purple	TURN SWITCH FEED	Turn Signal feed into Steering Column from the Turn Signal Flasher.
17A	White	BRAKE SW	12V input from Brake Switch #1 to Turn Signal Switch for Rear Brake Lights.
17B	LT Blue	THIRD BRAKE LIGHT	12V feed to the optional Third Brake Light.
18	Yellow	LEFT REAR TURN	Feed to LH Rear Turn Signal Lamp.
19	Dark Green	RIGHT REAR TURN	Feed to RH Rear Turn Signal Lamp.
27	Brown	TURN SW-HAZARD	Hazard feed to the Steering Column from the Hazard Flasher.
28	Black	HORN RELAY GROUND	Horn Relay ground to Horn Switch.
28A	Black	HORN RELAY GROUND	Horn Switch to ground, used for 1965 vehicles only.

Brake Switch #2 (Stop Light) Connector (65) for 1965 vehicles; plug this connector to the Brake Light Switch which is mounted to the Brake Pedal Assembly.

17C	White	BRAKE SW	12V input from Brake Switch #2 to Turn Signal for Rear Brake Lights.
40D	Orange	BRAKE SW	Fused Battery feed from the Fuse Block.

Circuit Branch 2 - Under Dash Connections

Dimmer Switch Route the wiring branch to the Dimmer Switch and use the existing Wiring clips on the side cowl to retain the wiring. Plug this connector onto the Dimmer Switch 500042, and then attach the Dimmer Switch to the floor pan. The Dimmer Switch will be mounted 180 degrees from the original Dimmer switch location but still using the same attachment holes. This will allow the wiring connection to the switch adequate clearance to the sheet metal.

Wire #	Wire Color	Printing	Description
10	Yellow	DIMMER SW FEED	Feed from the Headlight Switch.
11A	Light Green	HEADLIGHT-HI BEAM	Feed to LH Headlight High Beam.
11B	Light Green	HI BEAM INDICATOR LIGHT	Feed to the Hi Beam Indicator Light.
12	Tan	HEADLIGHT-LOW BEAM	Feed to LH Headlight-Low Beam.

Circuit Branch 2 - Under Hood Wiring LH and RH Engine Compartment Route the two Engine Compartment wiring branches through the two grommets G in the Firewall. The RH Engine Compartment Wiring routes through the upper Grommet and the LH Engine Compartment Wiring routes through the lower grommet.

Circuit Branch 2 - Under Hood Connections LH Engine Compartment (Drivers Side) Route this branch through the lower grommet in the Firewall and connect as follows.

NOTE: If you choose to upgrade your single reservoir Brake System to an upgraded dual reservoir Brake System, we have provided the circuits in the Dash Harness for a Brake Warning Light (Dash lamp and switch/switch connection not provided in kit).

The Brake Pressure Differential Warning Switch **NOTE:** if you have a Ford style twin post switch and wish to use it, simply cut the wires about 6 inches back from your old original connector, double them together, and splice them into wire assembly 33 B (from page 3 of this instruction sheet) to complete your brake warning circuit. If you have an aftermarket single post switch splice it into wire assembly 33 B (from page 3 of this instruction sheet) to complete your brake warning circuit (also see Figure A on page 10).

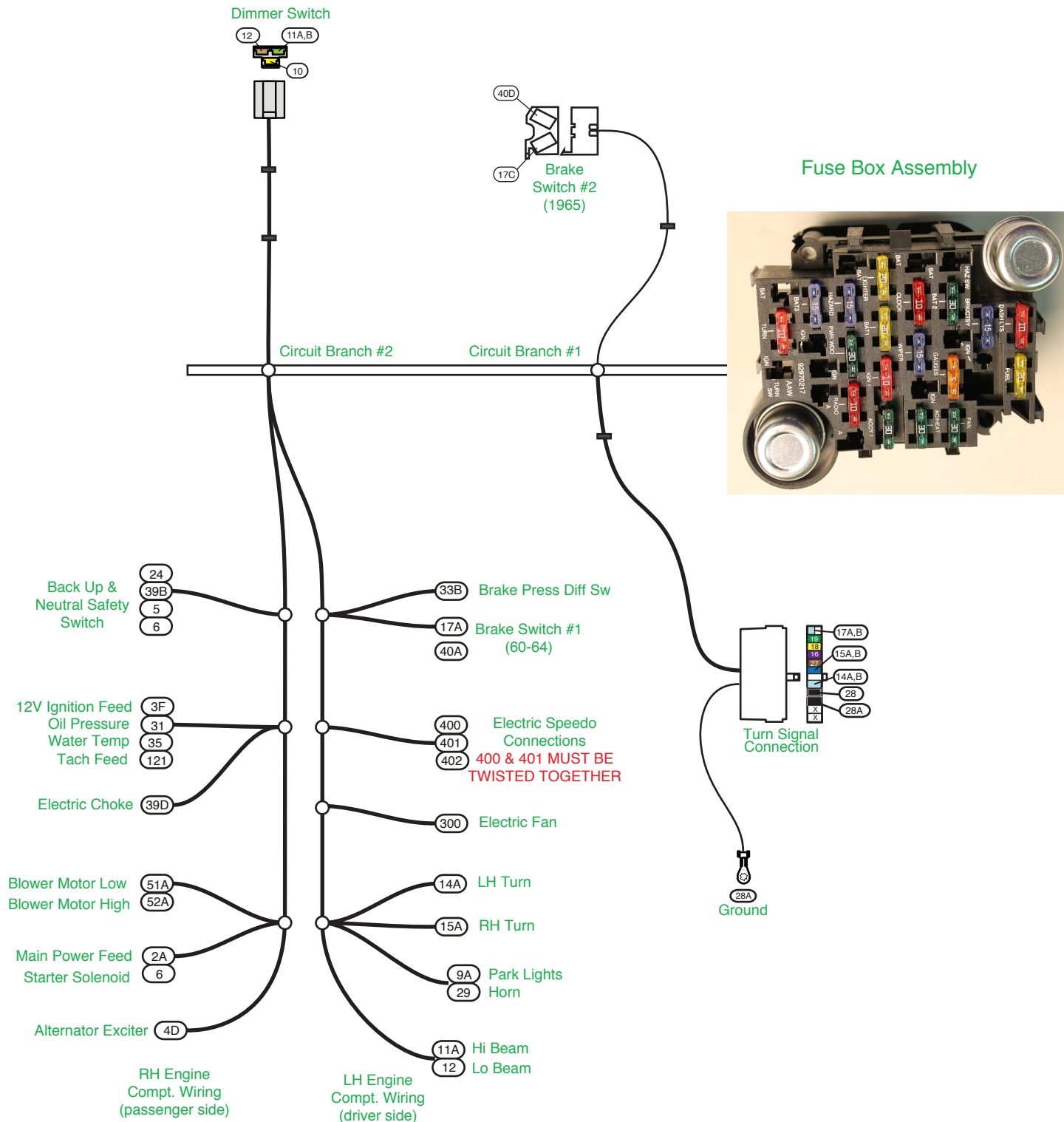

www.americanautowire.com 856-933-0801

PART # **510386**

DESCRIPTION:

1965 Ford Falcon

Classic Update Series Kit

92970579 Rev. 4.0 1/23/2018

Dash/Main Harness Installation Instructions

Circuit Branch 2 - Under Hood Wiring LH and RH Engine Compartment (cont'd)

Route wire 33B from the Dash Harness to the master cylinder area, cut to length, and splice it to the Brake Pressure Differential Warning Switch Extension (if needed).

Wire # Wire Color Printing Procedure

33B TAN BRAKE LIGHT/SWITCH Brake Warning feed.

Brake Switch #1 (Stop Light) Connection (60-64) If you have a 1960-64 vehicle; obtain circuits 17A and 40A and route them to the Brake Light Switch (Stop Light), which is attached to the Master Cylinder, cut to length, and slide on sleeve D to each branch, crimp on terminal X to each branch and attach to the Brake Light Switch. Polarity does not matter. (see figure A page 10)

17A White BRAKE SW Feed to the Turn Signal Switch.

40A Orange BRAKE SW Fused Battery feed from the Fuse Block.

Aftermarket Electric Speedometer Connect to your Electric Speedometer per the manufacturers recommendations. Note that wires 400 and 401 must remain twisted together.

400 Yellow VSS GROUND Vehicle Speed Sensor Ground.

401 Purple VSS SIGNAL Vehicle Speed Sensor Signal.

402 Purple/White VSS POWER Vehicle Speed Sensor Power if using a 3 wire sender.

Aftermarket Electric Fan This circuit is provided to feed the ignition trigger wire of your Electric Fan Relay (not provided with this kit). See the Electric Fan Manufacturers recommendations for electrical hook up. **This is a keyed hot feed.**

300 Orange ELECTRIC FAN Feed to the ignition trigger wire of the Electric Fan Relay.

Headlight Bucket Harnesses Obtain the Headlight Bucket Kit 510382 (Bag N) and follow the instructions to connect to your LH and RH Headlights.

Headlights Select the light green Headlight High Beam wire (11A) and the tan Headlight Low Beam wire (12). Route these wires to the LH Headlight Bucket Harness, cut each to length, take each of the cutoff portions, double each of them together with their original wires, crimp on terminal "C" to each pair of wires, and install each terminal into connector Z found in kit 510384 (see figure A on page 10). Be sure to align the tan wire 12 with the Headlight Bucket tan wire and the light green wire 11A to the Headlight Bucket light green wire. Now plug this connector to the LH Headlight Bucket Harness. Attach the black ground wire, with the ring terminal, from the LH Headlight Bucket Harness to a good body ground. Take the remaining light green and tan wires and route them to the RH Headlight Bucket Harness. Cut each to length, crimp on terminal B to each one, and install into another connector Z. Align the wire colors as before. Plug this connector to the RH Headlight Bucket Harness. Attach the black ground wire, with the ring terminal, from the RH Headlight Bucket Harness to a good body ground.

11A Lt Green HEADLIGHT-HI BEAM High Beam feed to the LH headlight.

12 Tan HEADLIGHT-LOW BEAM Low Beam feed to the LH headlight.

Park/Turn Lamp & Socket Assemblies **NOTE:** You will need to reuse the original Park/Turn Signal Lamp & Socket Assemblies, but will have to replace each 2-way bullet connector with a 2-way AAW connector (see figure A on page 10). Be sure that the Park/Turn Signal Lamp pigtail is routed and retained, per the original factory routing, before replacing the connectors. For both LH and RH Park/Turn Lamp & Socket Assemblies, remove the old 2-way molded bullet connectors, and install terminals W to each wire and install the wires in the 2-way connector "V" (all supplied in kit 510384) as shown in figure A on Page 10. The original Ford Left Front Turn wire is green/white and the Park Light wire is black/yellow. The original Ford Right Front Turn wire is white/blue and the Park Light wire is black/yellow.

Left Hand & Right Hand Park/Turn Lamp Connectors Select the brown Park Light wire (9A), route the wire close to the 2-way connector V that was just added to the LH Park/Turn Signal Lamp & Socket Assembly, cut to length, take the cut off portion, double them together in terminal C and install into connector T (see page 10 Figure A). Be sure to align the AAW brown Park Light wire with the original Park Light wire. Route the remaining brown wire close to the 2-way connector that was just added to the RH Park/Turn Signal Lamp & Socket Assembly. Crimp on terminal B, and install into another connector T. Select the light blue Left Front Turn wire (14A), route this wire to the same connector T where wire 9A is located. Crimp on terminal B and install in that connector T (see page 10 Figure A). Now make the connection to the LH Park/Turn Lamp & Socket Assembly.

Select the Right Front Turn wire (15A) and route it to the 2-way connector V that was added to the RH Park/Turn Signal Lamp & Socket Assembly. Cut to length, crimp on terminal B and install into connector T (see page 10 Figure A) where the brown park light wire is already located. Now make the connection to the RH Park/Turn Lamp & Socket Assembly. Be sure to align the AAW Park Light wire (brown) with the Ford Park Light wire (black/yellow), the AAW Left Turn wire (Lt Blue) with the Ford Left Turn wire (green/white), and the AAW Right Turn wire (DK Blue) with the Ford Right Turn wire (white/blue).

9A Brown PARK LIGHTS Park Light feed.

14A Lt Blue LEFT FRONT TURN Left Turn Signal feed.

15A Dk Blue RIGHT FRONT TURN Right Turn Signal feed.

Horn Connection Route wire (29) to the LH Horn and cut to length, double with the wire that was just cut, crimp on terminal "C" and insert into connector "N" and attach to the LH Horn. Route the loose wire to the RH Horn and crimp on terminal "B" and insert into connector "N" and attach to the RH Horn. If there is only one Horn, route the wire to the Horn and use terminal B and connector N. All of the terminals and connectors will be found in kit 510384. (see figure A page 10)

29 Dark Green HORN Horn feed.

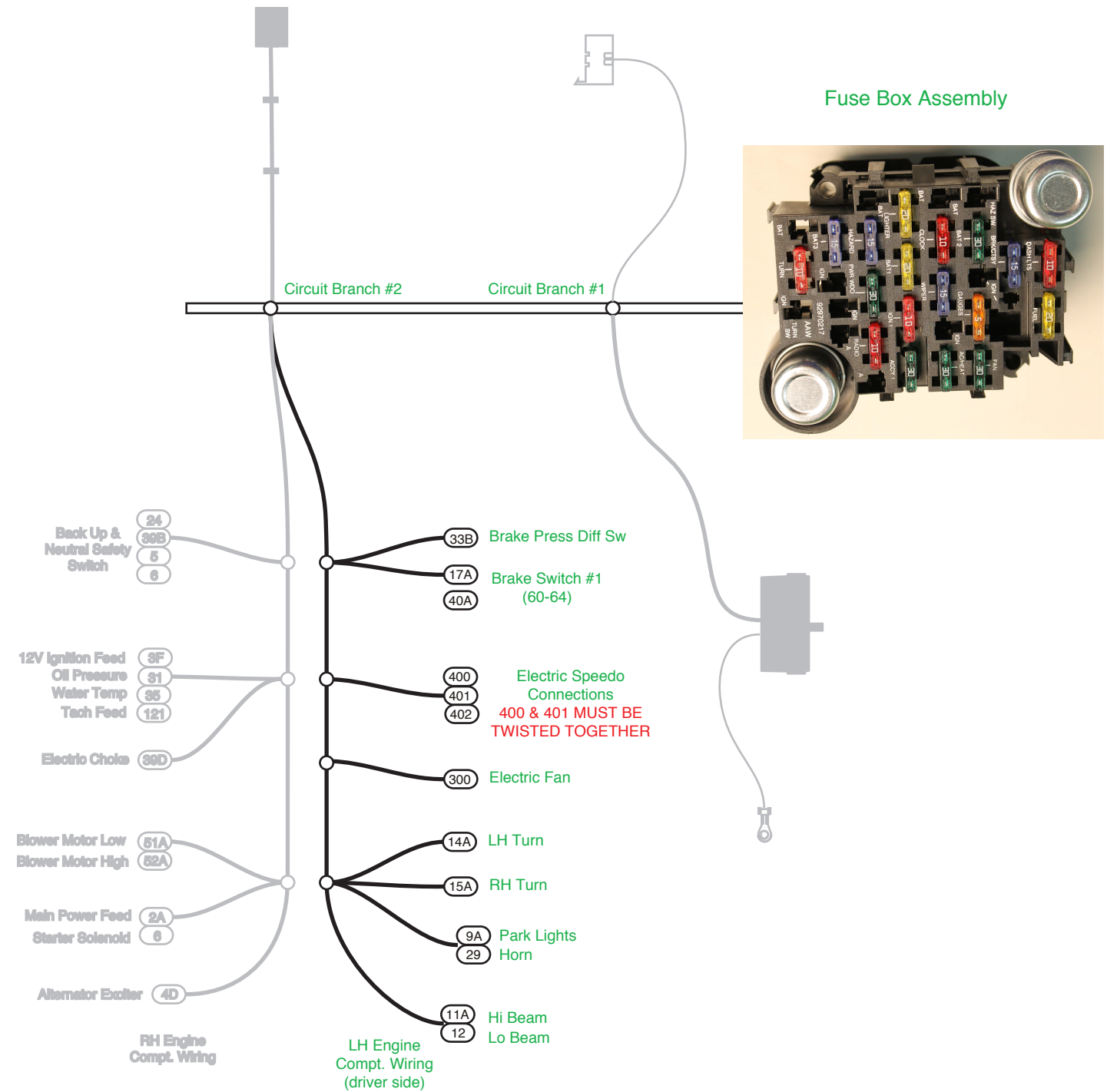

www.americanautowire.com 856-933-0801

PART # **510386**
 DESCRIPTION:
1965 Ford Falcon
Classic Update Series Kit
 92970579 Rev. 4.0 1/23/2018

Dash/Main Harness Installation Instructions

Circuit Branch 2 - Under Hood Connections RH Engine Compartment (Passenger Side) Route this branch through the upper grommet in the Firewall and connect as follows.

The Back-up and Neutral Safety Switches Route circuits 24 and 39B to the Back-up Lamp Switch and connect. If you have an Automatic Transmission, route circuits 5 and 6 to the Neutral Safety Switch and connect. If you have a Manual Transmission, connect wire 5 to wire 6. **Note: If wire 5 and wire 6 are not connected your starter solenoid will not engage and your engine will not crank.** A typical aftermarket connection for the Neutral Safety/Back-up Switch can be found on page 11, Figure D.

Wire #	Wire Color	Printing	Procedure
5	Purple	NEUTRAL SAFETY SWITCH	Start feed from the Ignition Switch to the Neutral Switch or to wire 6.
6	Purple	STARTER SOLENOID-S	Start circuit from the Neutral Safety Switch or wire 5 to the Starter Solenoid.
24	Lt Green	BACK UP LT SW	Feed from the Back-up Lamp Switch to the Back-up Lamps.
39B	Pink	BACK UP LT SW	Feed from the Back-up Lamp Switch.

Ignition Feed This is your 12V switched power source for the distributor /coil. This can be connected directly to the "Bat" terminal on a typical HEI Distributor, to a Ballast Resistor for a point's type Distributor, or to be used as the ignition power source for an Aftermarket Ignition Module such as an MSD or "Dura Spark" module. See the installation instructions for the type of Distributor you are using for specific connection requirements. If you are using a GM style HEI distributor, terminal C and connector P (see Parts Kit 510384) have been provided to make that connection (see page 11 figure B for some examples).

3F	Pink	IGNITION FEED	Switched 12V Feed for the ignition.
----	------	---------------	-------------------------------------

Engine Sensors and Electric Choke Route the 31 and 35 wires to the Oil Pressure and Water Temperature Sending Units respectively, cut to length, install terminals B or M (install sleeve J first if using M), plug into connector N (if using terminal B), see page 11 Figure B. See parts kit 510384 for connectors and terminals. Route the 39D wire to the Electric Choke (if equipped), no mating connectors or terminals have been provided for the Electric Choke.

31	Dark Blue	OIL PRESSURE SENDER	Oil Pressure Sending unit.
35	Dark Green	WATER TEMP SENDER	Water Temperature Sending unit.
39D	Tan	ELECTRIC CHOKE	On carbureted vehicles, connect to the Electric Choke.

Tachometer This Kit will not support the use of an original factory tachometer (see the Warning Page). However, this can be connected directly to the Tachometer terminal on a typical HEI Distributor, to the negative side of the Ignition Coil, or a Tachometer connection in an aftermarket Ignition Module such as an MSD module. If you are using a GM style HEI Distributor, terminal B and connector Q (Parts Kit 510384) have been provided to make that connection (see page 11, figure B).

121	White	COIL-->TACH	Tachometer feed wire.
-----	-------	-------------	-----------------------

Blower Motor Connector Connect to the Blower Motor Pigtail wires. Route wire 51A and 52A to the Blower Motor and cut to length. Slide on sleeve D and then crimp on terminal X to each wire (see page 11 figure B). Now connect to the Blower Motor Pigtail Wires (red to red and orange to orange), there is also a separate ground wire from the Blower motor which will have to attach to a good ground.

51A	Red	no printing	Blower Motor Low speed.
52A	Orange	no printing	Blower Motor High speed.

Starter Relay Connections Route wires 2A and 6 to the Starter Motor Relay.

Main Power Feed to the Fuse Block Route wire 2A from the Dash Harness to the Megafuse assemblies and cut to length. Install the ring terminal and shrink tube found in kit 510476 and connect to the Megafuse assemblies per the 510476 (92972153) instructions. See referenced details on page 11, figure C.

2A	Red	12V BATTERY	Main power feed.
----	-----	-------------	------------------

Start Circuit Route wire 6 to the Starter Relay and cut to length. Install sleeve D and crimp on terminal K (see parts kit 510384). Connect to the Starter Solenoid S stud (see page 11, figure B).

6	Purple	STARTER SOLENOID-S	Start circuit.
---	--------	--------------------	----------------

Alternator Output Circuit Alternator Power Wire can be found in the Alternator and Main Power Connection kit 510476.

Alternator Exciter Wire The wire 4D is the exciter wire for your Alternator/Voltage Regulator. If you are using a one wire Alternator, this wire will not be used and should be capped off as it is "hot" in the ignition "on" position. If you are using an Alternator that requires an internal or external Voltage Regulator, this wire must be connected to the "switched or 12V ignition" terminal on your Voltage Regulator or Alternator according to the manufacturers specifications for the type of Alternator/Voltage Regulator that is being used. An inline diode or resistor may be necessary to eliminate "run on" after being switched off. AAW recommends a GEN 3 Internally Regulated or one wire alternator. If you are using a GM "SI" alternator, obtain the GM "SI" Alternator Exciter Wiring Harness (see page 2). Attach the ring terminal end of wire 2G to the Alternator Battery stud. Route the 4D wire to the 2-way connector, which is part of the same Exciter Wiring Harness. Crimp on terminal B to wire 4D and insert into the open cavity of the 2-way connector. Now plug the 2-way connector into the "SI" alternator.

2G	Red	12V BATTERY	Battery wire for the GM "SI" Alternator Exciter Wiring Harness.
4D	Brown	ALTERNATOR IGN	Alternator Exciter wire.

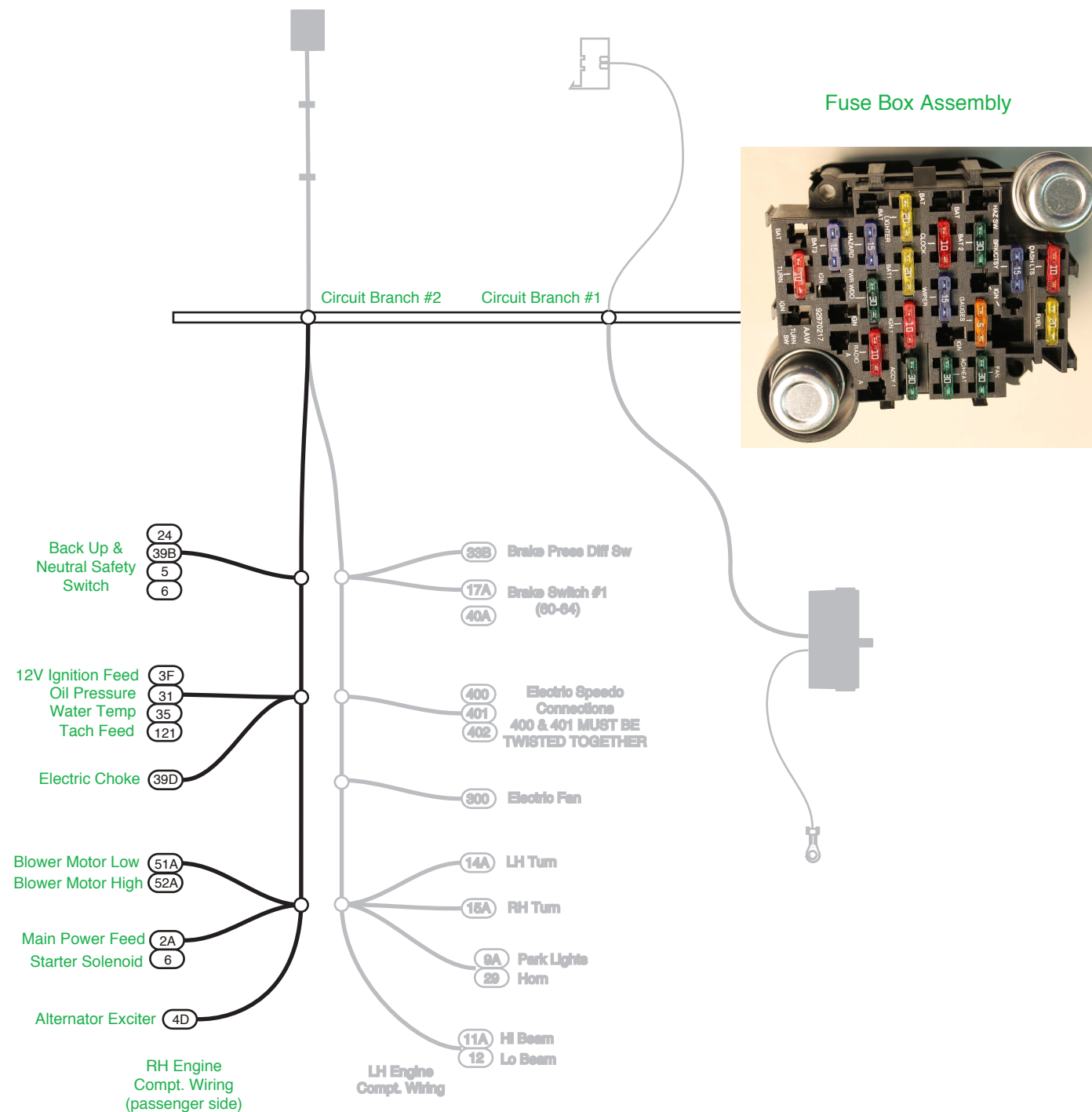

www.americanautowire.com 856-933-0801

PART # **510386**

DESCRIPTION:

1965 Ford Falcon

Classic Update Series Kit

92970579 Rev. 4.0 1/23/2018

Dash/Main Harness Installation Instructions

Circuit Branch 3 - Under Dash Connections

Rear Body Harness Connection This connector will plug to the Rear Body Harness 510383. Specific connections are addressed in that kit. The Rear Body Harness will route along the driver's sill the same as the original Ford Body Harness routing. Be sure to attach the wiring in the original routing clips.

9B	Brown	REAR RUNNING LIGHTS	Feed for the License Light and Rear Park Lights.
17B	Light Blue	THIRD BRAKE LIGHT	Feed for an aftermarket Third Brake Light.
17C	White	BRAKE SW	Brake Light Switch Feed to the Turn Signal Switch.
18	Yellow	LEFT REAR TURN	Feed to the Left Rear Stop and Turn Light.
19	Dark Green	RIGHT REAR TURN	Feed to the Right Rear Stop and Turn Light.
24	Light Green	BACK UP LT SW	Feed from the Back-up Light Switch to the Back-up Lights.
30	Tan	GAS GAUGE	Fuel Tank Sender.
40G	Orange	12V BATTERY-FUSED	12V Feed for the Trunk Light or aftermarket LED Rear Lights.
53C, 53D	Light Blue	12V CTSY SW	Feed to the Dome Light.

Left Hand Door Jamb Switch Connection Route the two bullet terminals through the Door Jamb switch hole from behind, and connect to the Door Jamb Switch 92964258 which is included in kit 510384. Polarity does not matter. Attach the Door Jamb Switch in the original location.

40H	Orange	12V BATTERY-FUSED	12V Fused Battery Feed.
53H	Light Blue	12V CTSY SW	Feed to the LH Courtesy Light.

Ignition Switch Connector Plug this connector to the Ignition Switch 510128.

2B	Red	12V BATTERY	12V un-fused battery feed from the Fuse Block.
3A	Pink	IGNITION FEED	Ignition feed to the Fuse Block.
5	Purple	NEUTRAL SAFETY SWITCH	Start feed to the Neutral Safety Switch or to wire 6.

Ignition Switch Accessory Ring Terminal Attach this ring terminal to the Ignition Switch after the Ignition Switch Connector is plugged in. Use the nut to securely fasten the ring terminal to the Ignition Switch threaded stud. **DO NOT OVERTIGHTEN.**

4A	Brown	IGNITION SW ACCY	Accessory feed to the Fuse Block.
4E	Brown	no printing	Accessory feed to the Cluster.

Ignition Switch 1-way Connector Connect this to the Ignition Switch after the Ignition Switch Accessory Ring Terminal is attached. this connector plugs onto the blade terminal which is located on the side of the Ignition Switch. This wire provides the bulb check ground for the Brake Warning Lamp circuit when the Ignition Switch is in the "Start" position.

33B,C	Tan	Brake Light/switch	Brake Warning Lamp bulb check during crank.
-------	-----	--------------------	---

Headlight Switch Connector Plug this connector to Headlight Switch 510385 (for 1960-1964 vehicles) or 510054 (for 1965 vehicles).

2F	Red	12V BATTERY	Un-fused 12V Battery feed from the Fuse Block.
9A	Brown	PARK LIGHTS	Feed to the Front Park Lights.
9B	Brown	REAR RUNNING LIGHTS	Feed to the Rear Tail Lights and the License Light.
10	Yellow	DIMMER SW FEED	Feed to the Dimmer Switch for the Headlights.
40C	Orange	12V BATTERY-FUSED	Fused 12V Battery feed from the Fuse Block.
40D	Orange	BRAKE SW	Feed to Brake Switch #2.
40E	Orange	12V BATTERY-FUSED	Feed to the Map Light or the Glove Box Light.
44	Dark Green	no printing	Feed to the Fuse Block for the Dash Lights.
53A	Light Blue	12V CTSY SW	12V Switched feed to the Map Light.
53B	Light Blue	12V CTSY SW	12V Switched feed to the Right Hand Courtesy Light.

Wiper Switch Connector This connector is the power feed for the Wiper System. You may wish to use the wiper circuits in your original harness or obtain an overlay harness from the aftermarket suppliers.

93	White	WIPER FEED	12V fused feed for the Wiper Switch Assembly.
----	-------	------------	---

Left Hand Courtesy Lamp Connector Plug into one Courtesy Light Extension, from bag G (as shown on page 2), to complete this circuit, and attach to the lower Instrument Panel.

53D, 53H	Light Blue	12V CTSY SW	12V Switched feed to the Left Hand Courtesy Light.
156A	White	CTSY GROUND	LH Courtesy Lamp ground. Attach this ring terminal to a good ground.

Map and Glove Compartment Connectors These connectors are provided for your optional Glove Box Light, Map Light, or Comet Door Courtesy Lights.

40E, H	Orange	12V BATTERY-FUSED	Feed for the Glove Box, Map, or Comet Door Courtesy Lights.
53A, C	Light Blue	12V CTSY SW	Feed for the Map or Comet Door Courtesy Lights.

NOTE: The courtesy lamp extension from page 2, that plugs onto the connector at branch 3 on this page, uses a # 631 bulb (not included with this kit). They may be purchased at any auto parts store.

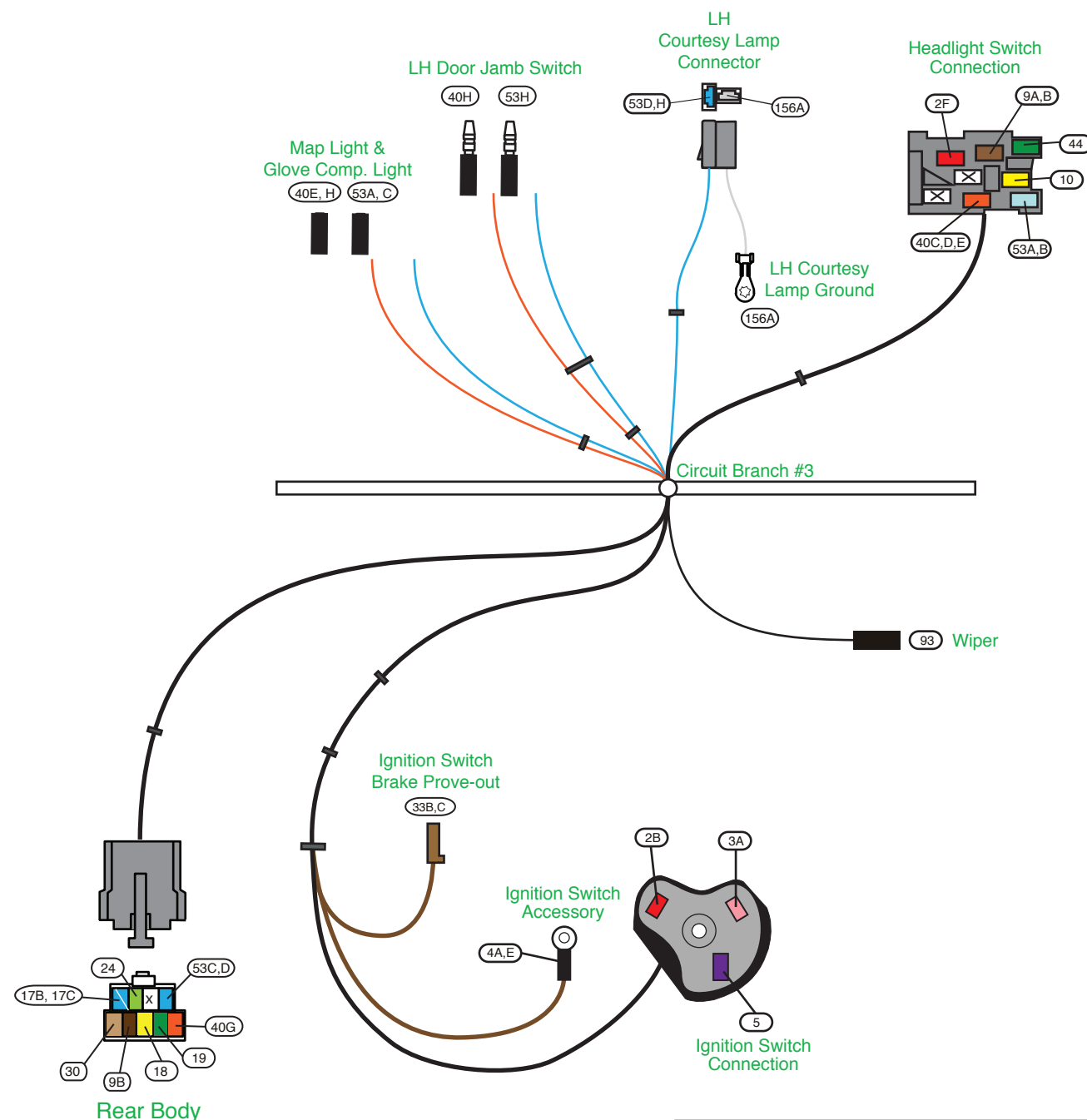

www.americanautowire.com 856-933-0801

PART # **510386**
 DESCRIPTION:
1965 Ford Falcon
Classic Update Series Kit

92970579 Rev. 4.0 1/23/2018

Dash/Main Harness Installation Instructions

Circuit Branch 4 - Under Dash Connections

Instrument Cluster Connections These connections will plug into the Cluster Connector Kit 510381. Instructions are included in that kit.

Wire# Wire Color Printing Procedure

Cluster Connector "A"

4E	Brown	no printing	Cluster 12V feed.
8A,B	Gray	DASH LIGHTS	Fused 12V from the Fuse Block for the Cluster Illumination Lights.
39A	Pink	12V IGNITION	Fused 12V for the Oil Pressure Lamp or Aftermarket Gauges.
150	Black	GROUND	Cluster ground.

Cluster Connector "B"

11B	Light Green	HI BEAM INDICATOR LIGHT	Feed to the High Beam Indicator Light.
14B	Light Blue	LEFT DASH IND	Feed for the Left Turn Signal.
15B	Dark Blue	RIGHT DASH IND	Feed for the Right Turn Signal.
30	Tan	GAS GAUGE	Fuel Sender signal from the Fuel Tank Sending Unit.
31	Dark Blue	OIL PRESSURE SENDER	Oil Pressure Sender signal from the engine.
33C	Tan	BRAKE LIGHT/SWITCH	Brake Warning feed.
35	Dark Green	WATER TEMP SENDER	Water Temperature Sender signal from the engine.
121	White	COIL->TACH	Feed for an Aftermarket Tachometer (see the Warning Sheet).

Cluster Connector "C" This connector contains the circuits for an Aftermarket Electric Speedometer. Wires "400" and "401" must remain twisted together.

139	Pink/White	SPEEDO POWER	Fused 12V feed for the Electric Speedometer.
151	Black/White	SPEEDO GROUND	Electric Speedometer ground.
400	Yellow	VSS GROUND	Vehicle Speed Sensor ground.
401	Purple	VSS SIGNAL	Vehicle Speed Sensor signal.
402	Purple/White	VSS POWER	Vehicle Speed Sensor power.

Aftermarket Electric Speedometer Ground Attach this wire to a good body ground. Note: Do not attach this ring terminal with the "150" ground ring terminal in Circuit Branch #5.

151	Black/White	SPEEDO GROUND	Ground for an Aftermarket Electric Speedometer.
-----	-------------	---------------	---

Circuit Branch 5 - Under Dash Connections

Heater Blower Switch #1 Connectors (60-63) for 1960-63 vehicles connect these 1-way connectors to the Heater Blower Switch (see Figure E).

50,50A	Brown	HEATER/AC FEED	Fused Ignition Feed from the Fuse Block.
51	Red	no printing	Heater Blower low speed.
52	Orange	no printing	Heater Blower high speed.

Heater Blower Switch #2 Connector (64-65) for 1964-1965 vehicles connect this 3-way connector to the Heater Blower Switch.

50A	Brown	HEATER/AC FEED	Fused Ignition Feed from the Fuse Block.
51,51A	Red	no printing	Heater Blower low speed.
52,52A	Orange	no printing	Heater Blower high speed.

Cigar Lighter Connector Plug this connector to the Cigar Lighter.

40B	Orange	no printing	12V Battery feed to the Cigar Lighter.
-----	--------	-------------	--

Radio or Clock These circuits are provided for your Radio and/or Clock.

43	Tan	RADIO	12V fused Accessory feed for Radio "on/off" power.
99	Yellow	RADIO BAT	12V fused Battery feed for Radio memory or a Clock.

Ground Lead Attach this wire to a good body ground. Note: Do not attach this ring terminal with the 151 ground wire in Circuit Branch #4.

150	Black	GROUND	Cluster ground.
-----	-------	--------	-----------------

Dash Light Candelabra Attach the Ash Tray Light, Radio Illumination Light, Clock Light, Vacuum Gauge Light, Tachometer Light, or Comet Transmission Selector Dial Light to this candelabra connector. Note: If needed, male bullet terminals A and sleeves J have been provided to replace your original terminals. They can be found in the 510384 Parts Kit.

8B	Gray	DASH LIGHTS	Various Dash Lights feeds.
----	------	-------------	----------------------------

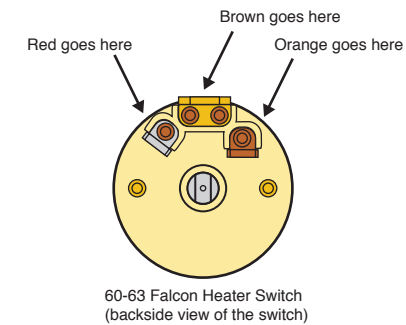
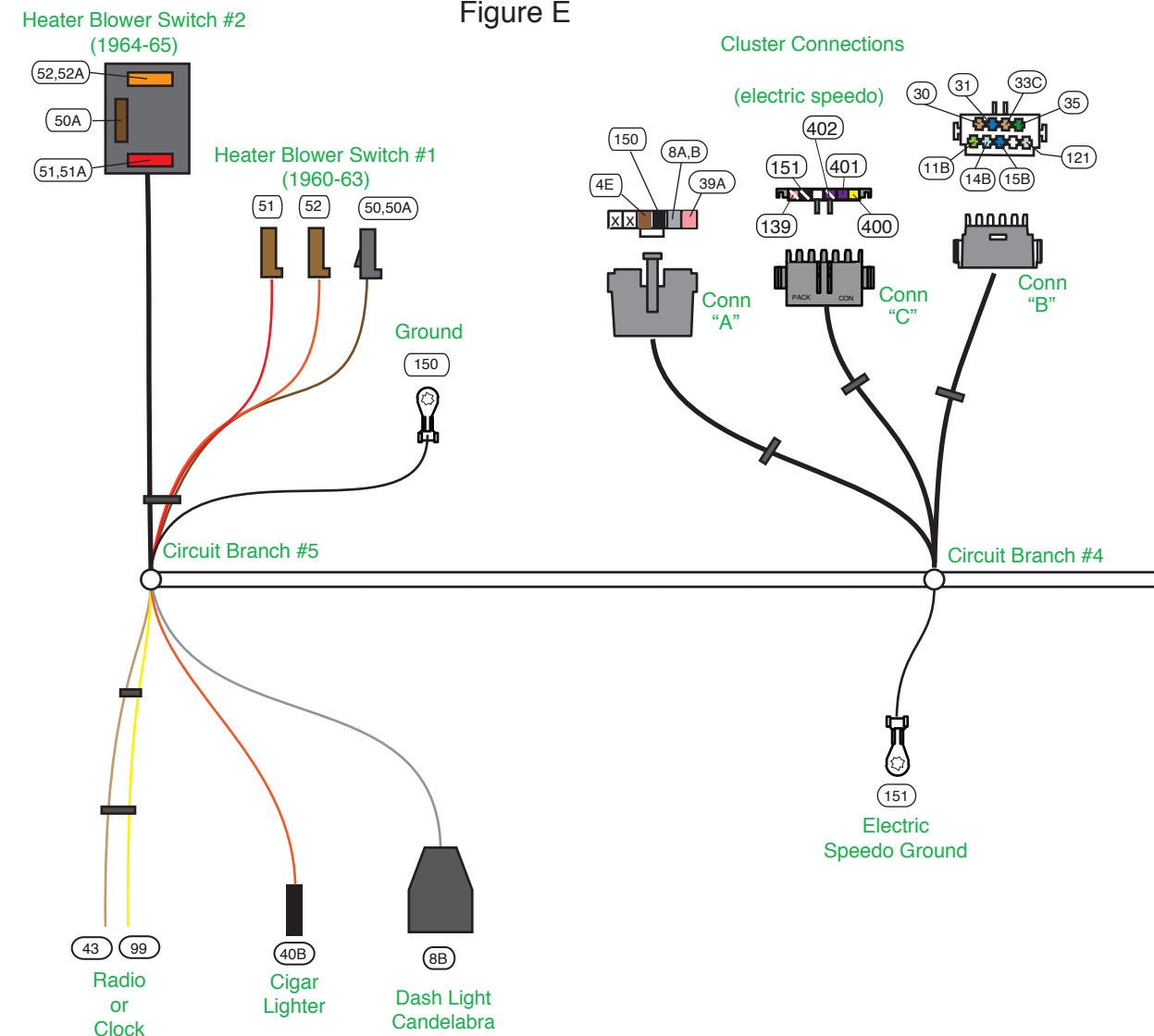

Figure E



www.americanautowire.com 856-933-0801

PART # **510386**
 DESCRIPTION:
1965 Ford Falcon
Classic Update Series Kit
 92970579 Rev. 4.0 1/23/2018

Circuit Branch 6 - Under Dash Connection

Accessory Connector Use the provided 6-way empty connector, which is attached to the 6-way connector on the Dash Harness, and terminals B or C (see kit 510384) to add power leads (not provided) for the following systems:

Wire#	Wire Color	Printing	Fuse Block	Rating	Description
100	Orange	no printing	BAT3	15A	Battery feed for Audio systems.
103	Tan	FUEL PUMP	FUEL	20A	Ignition feed for Electric Fuel Pump.
104	Orange	POWER SEATS	BAT2	30A	Battery feed for Power Seats.
105	Red	POWER LOCKS	BAT1	20A	Battery feed for Power Locks.
106	Pink	POWER WINDOWS	PWR WDO	30A	Ignition feed for Power Windows.
107	Brown	no printing	ACCY 1	30A	Accessory feed for Cruise Control or options.

Horn Relay Connector Plug the Horn Relay (found in the 510353 Fuse kit) into this connector.

Wire#	Wire Color	Printing	Procedure
2D	Red	12V BATTERY	12V Battery feed to the Horn Relay.
28	Black	HORN RELAY GROUND	Relay ground circuit (to Steering Column).
29	Dark Green	HORN	Feed to the Horn.

Circuit Branch 7 - Under Dash Connections

Right Hand Courtesy Lamp Connector Plug into one Courtesy Light Extension from bag G (as shown on page 2), to complete this circuit, and attach to the Lower Instrument Panel.

Wire#	Wire Color	Printing	Procedure
53B,E	Light Blue	12V CTSY SW	Feed to the Right Hand Courtesy Lamp.
156B	White	CTSY GROUND	RH Courtesy Lamp ground. Attach this ring terminal to a good ground.

Right Hand Door Jamb Switch Connection Route the two bullet terminals through the Door Jamb Switch hole from behind, and connect to the Door Jamb Switch 92964258 which is included in kit 510384. Polarity does not matter. Attach the Door Jamb Switch in the original location.

40F	Orange	12V BATTERY-FUSED	12V Fused Battery feed.
53E	Light Blue	12V CTSY SW	Feed to the RH Courtesy Light.

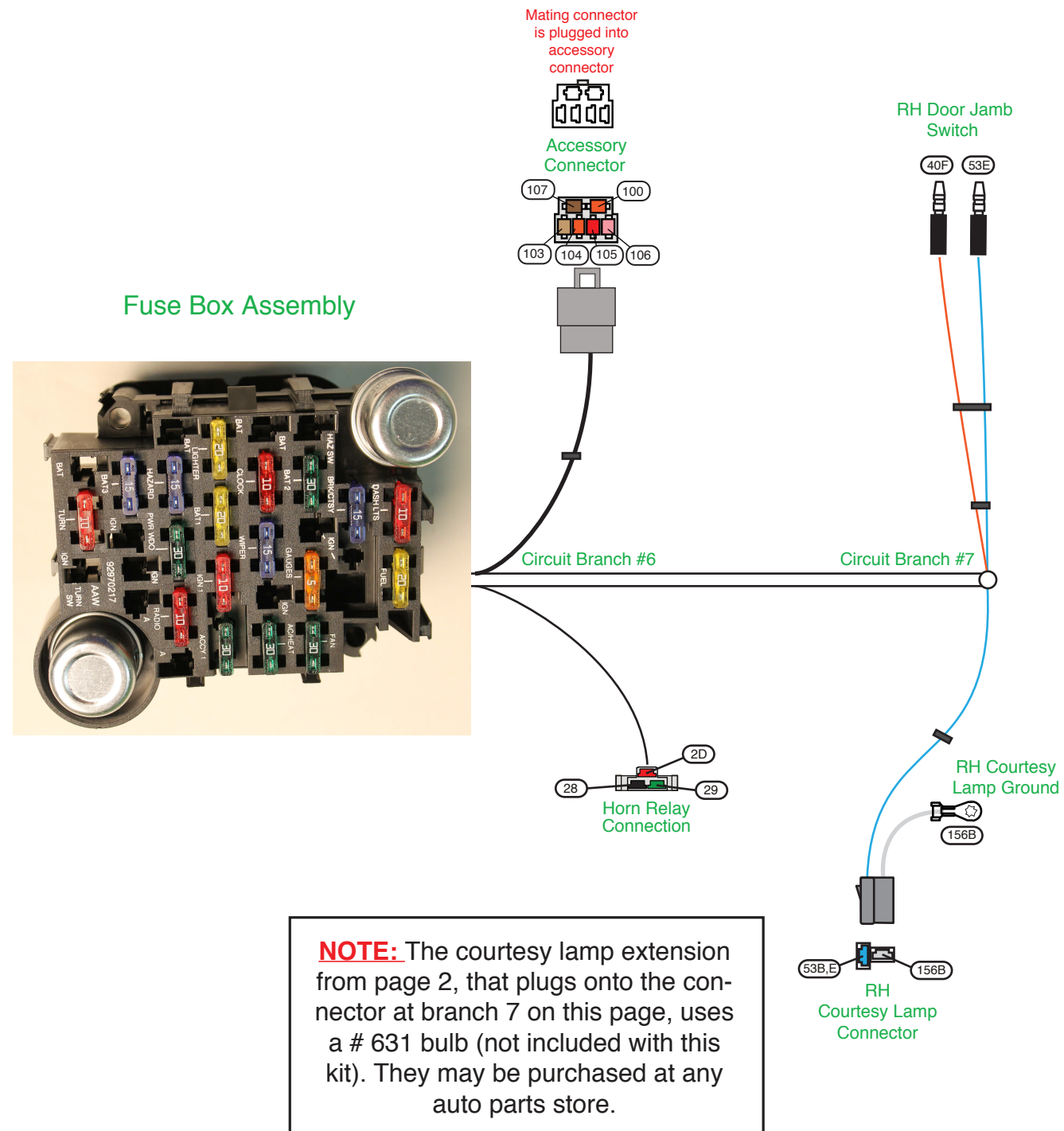

NOTE: The courtesy lamp extension from page 2, that plugs onto the connector at branch 7 on this page, uses a # 631 bulb (not included with this kit). They may be purchased at any auto parts store.



www.americanautowire.com 856-933-0801

PART # **510386**
 DESCRIPTION:
 1965 Ford Falcon
 Classic Update Series Kit
 92970579 Rev. 4.0 1/23/2018

AMERICAN AUTOWIRE DASH HARNESS CONNECTION

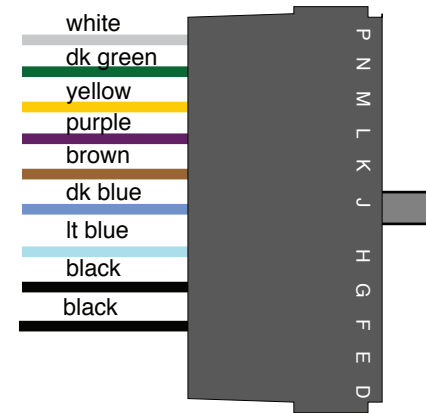

ORIGINAL TURN SIGNAL SWITCH WIRING

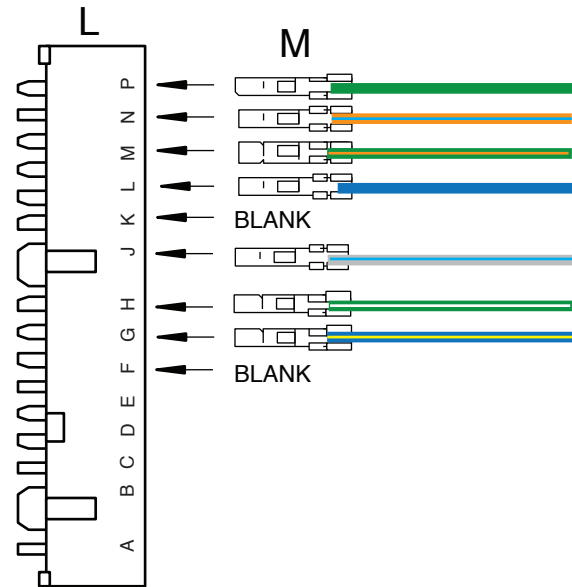
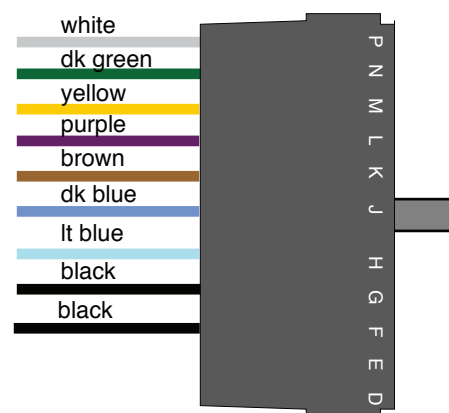

DIAGRAM 'A' - AAW Turn Signal Switch Wires to Stock 1960-64 Steering Columns.

AMERICAN AUTOWIRE DASH HARNESS CONNECTION



ORIGINAL TURN SIGNAL SWITCH WIRING

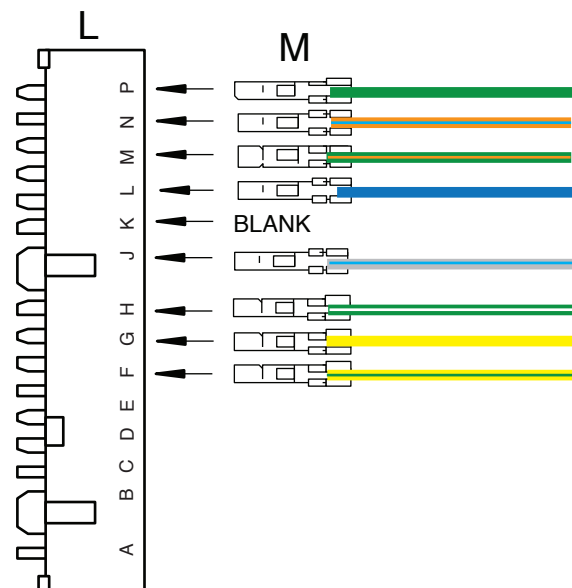

DIAGRAM 'A' - AAW Turn Signal Switch Wires to Stock 1965 Steering Columns.

"Table A"

AAW Turn Signal Switch wires to stock 1960-64 Ford Turn Signal Switch

AAW Wire #	AAW Wire color	AAW Wire Printing	Ford Wire Color
14A,B	Light Blue	Left Front Turn	Green with white stripe.
15A,B	Dark Blue	Right Front Turn	White with blue stripe.
16	Purple	Turn Switch Feed	Blue.
17A,B	Blue & White	Brake Switch	Green.
18	Yellow	Left Rear Turn	Green with orange stripe.
19	Dark Green	Right Rear Turn	Orange with blue stripe.
27	Brown	Turn SW - Hazard	not available
28	Black	Horn Relay Ground	Blue with yellow stripe.
28A	Black	Horn Relay Ground	not available

NOTE: For these vehicles, the Steering Column Horn Button switches ground on wire #28 (28A not used) for a Horn Relay, which then switches power to the Horns, similar to the AAW design. Circuit 27 is being provided if an Emergency Warning Flasher System is to be added. Circuit 28A is provided for the 65 vehicles (see below) and is not used for the 60-64 vehicles.

AAW Turn Signal Switch wires to stock 1965 Ford Turn Signal Switch

AAW Wire #	AAW Wire color	AAW Wire Printing	Ford Wire Color
14A,B	Light Blue	Left Front Turn	Green with white stripe.
15A,B	Dark Blue	Right Front Turn	White with blue stripe.
16	Purple	Turn Switch Feed	Blue.
17A,B	Blue & White	Brake Switch	Green.
18	Yellow	Left Rear Turn	Green with orange stripe.
19	Dark Green	Right Rear Turn	Orange with blue stripe.
27	Brown	Turn SW - Hazard	not available
28	Black	Horn Relay Ground	Yellow.
28A	Black	Horn Relay Ground	Yellow with Green Stripe.

NOTE: For these vehicles, the Steering Column Horn Button switched 12V power to the Horns. The AAW design switches ground through the Steering Column Horn Button which grounds a Horn Relay that switches power to the Horns. Therefore, you will have to align the 28A wire to the Ford Yellow with a Green Stripe wire. Be sure to connect the ring terminal end of 28A to a good ground. Circuit 27 is being provided if an Emergency Warning Flasher System is to be added.



www.americanautowire.com 856-933-0801

PART # **510386**

DESCRIPTION:

1965 Ford Falcon

Classic Update Series Kit

92970579 Rev. 4.0 1/23/2018

510382 Headlight Bucket Kit

SEE THE INSTRUCTIONS FROM THE 510382 HEADLIGHT BUCKET KIT (BAG N) FOR SPECIFIC INFORMATION REGARDING THE PARTS BELOW

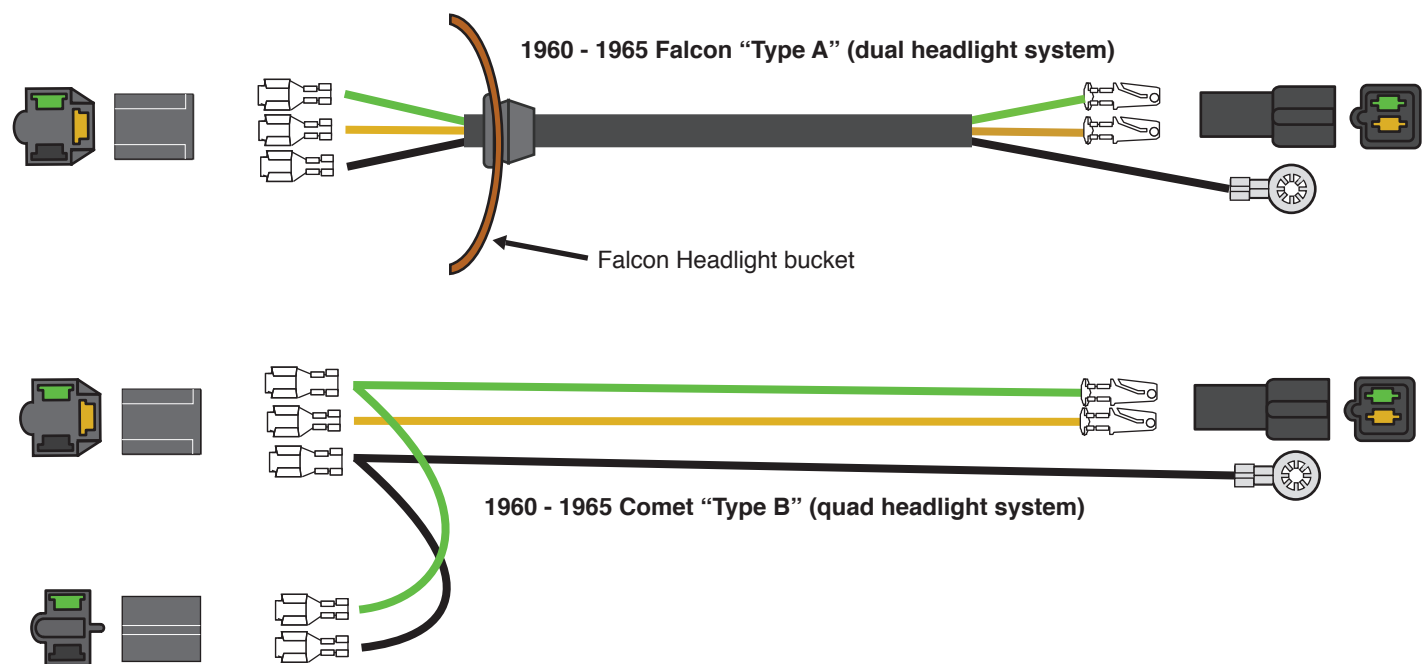
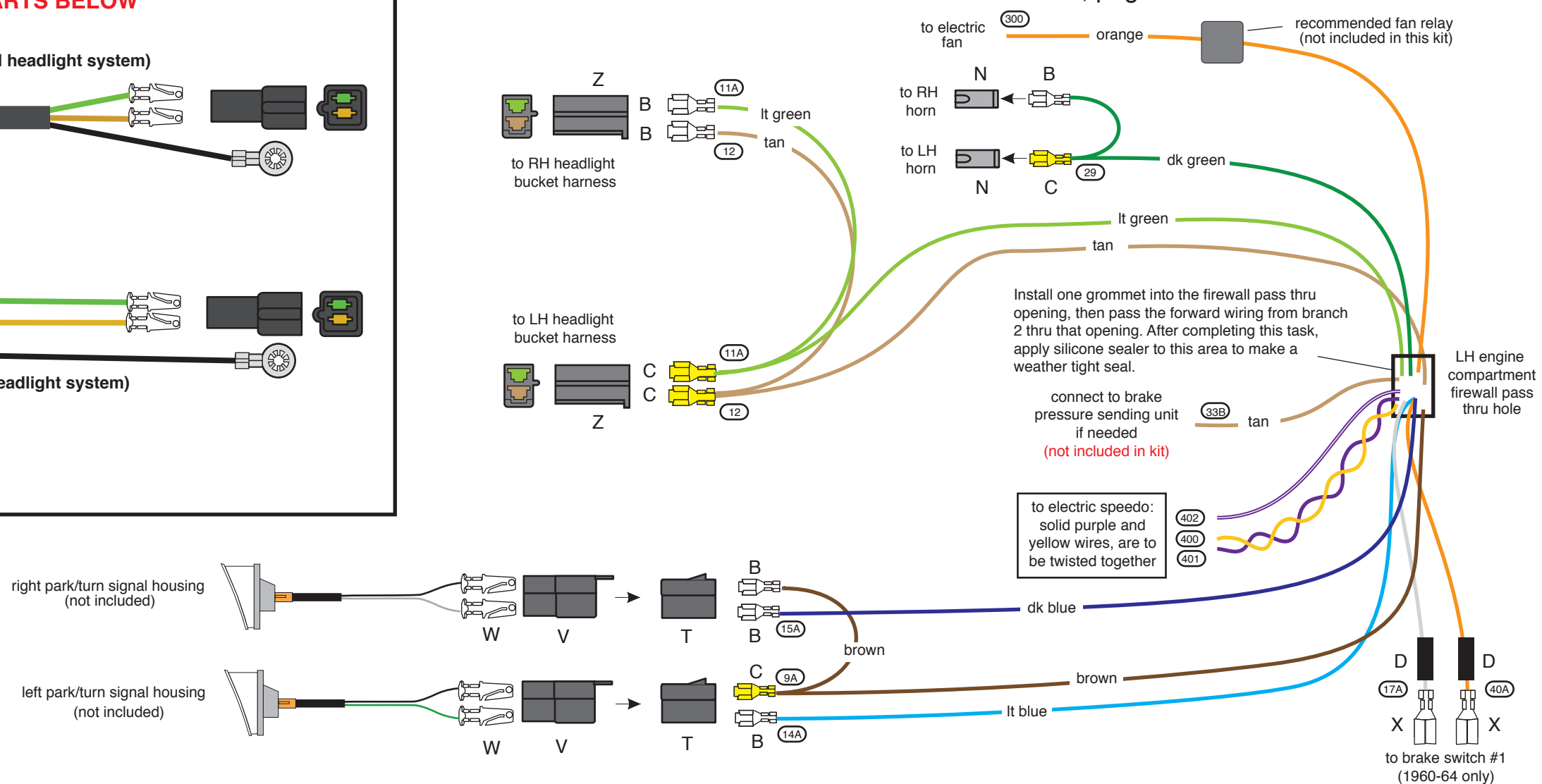

Figure "A"

Head lamp, parking lamp, horn, brake warning, fan relay, brake switch and electric speed. These wires are all found at branch 2, pages 3 and 4.



NOTE: The terminals and connectors listed on this page and denoted with UPPER CASE LETTERS, to help you complete the various connections to your lamps, horns, switches, etc., can be found in your loose piece clamp, grommet, and parts kit, P/N 510384.

The identifications, colors, and functions for all of the wires listed in "Figure A" on this page, can be found on pages 3 & 4, branch 2 of this instruction set and in the headlight bucket kit.



www.americanautowire.com 856-933-0801

PART # **510386**

DESCRIPTION:

1965 Ford Falcon

Classic Update Series Kit

92970579 Rev. 4.0 1/23/2018

Figure "B"
Right Hand
Engine Compartment

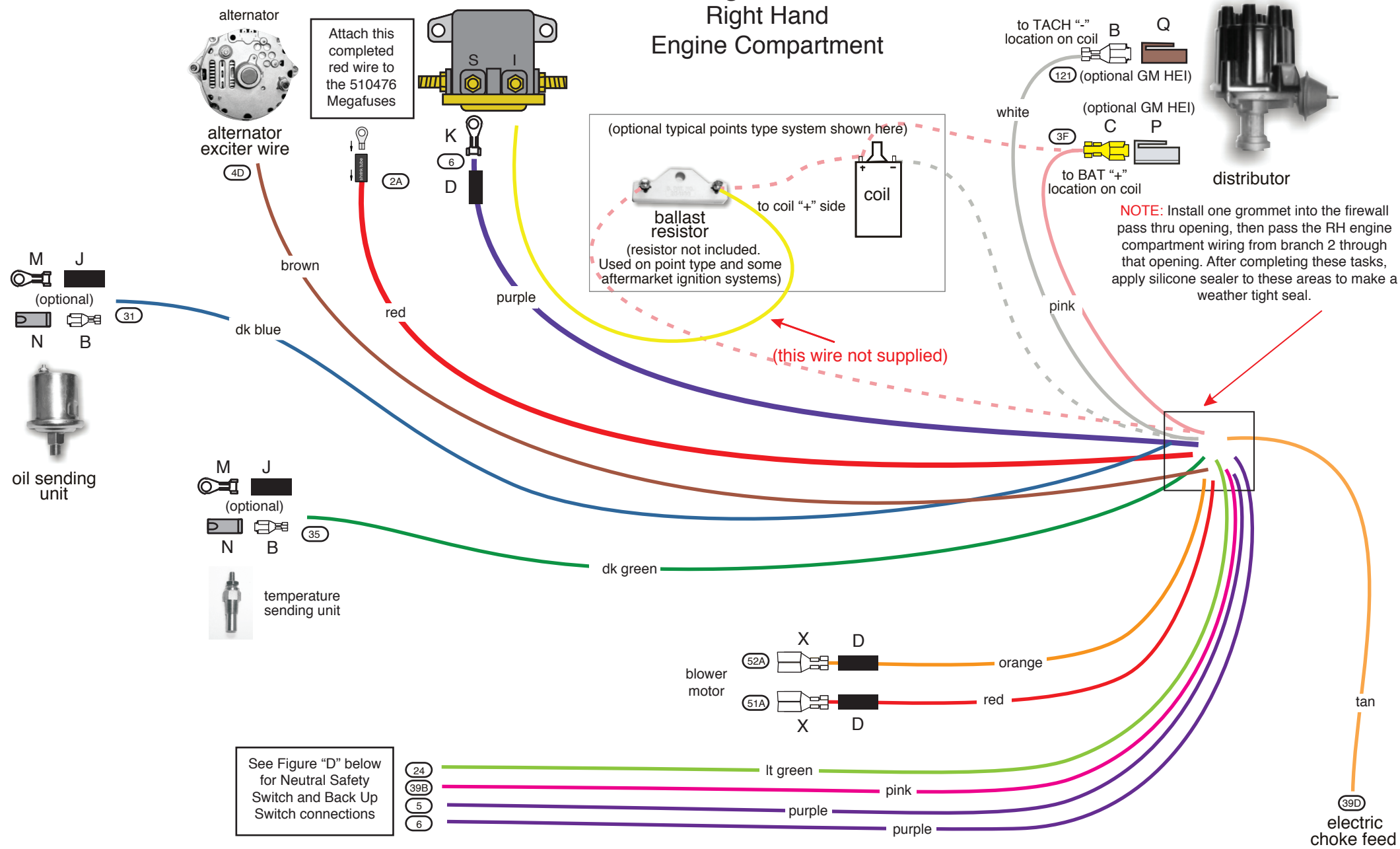

NOTE: The terminals and connectors listed on this page and denoted with **UPPER CASE LETTERS**, are to help you complete the various connections to your back-up and NSS switch, ignition feed, engine sensors, electric choke, tachometer, blower motor, main power, starter solenoid, alternator exciter, and alternator output. They can all be found in your loose piece clamp, parts kit, P/N 510384.

AAW suggests and recommends using page 5 to complete the installation of the RH engine compartment wiring.

AAW kits are all engineered to be used in conjunction with a high output, later model internally regulated, or one wire alternator. We do not suggest or support the use of a stock low amperage alternator as they do not supply sufficient current to recharge the battery in a highly modified car such as this kit was designed for. AAW suggests a Ford Gen III, a GM "SI", or a 1 wire type alternator as good choices to use. An adapter to complete the connection to the Ford Gen III style alternator (AAW p/n 500802) may be purchased separately. Contact AAW for your needs.

Figure "C"
Main Power and

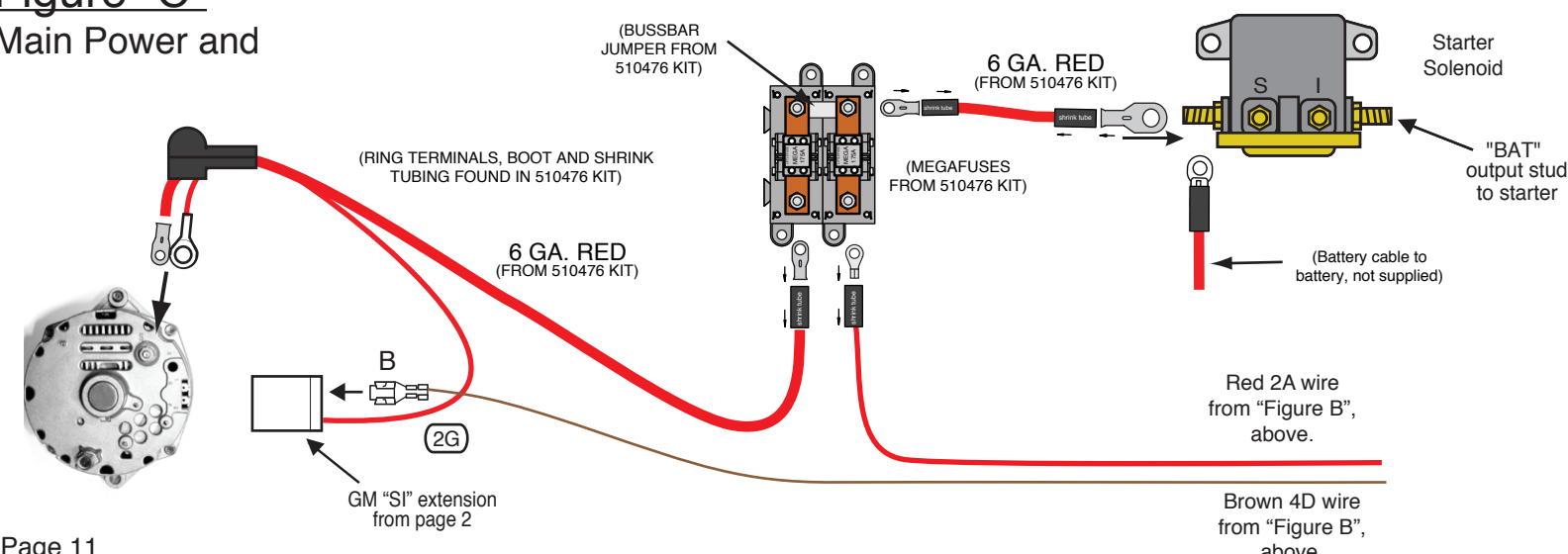
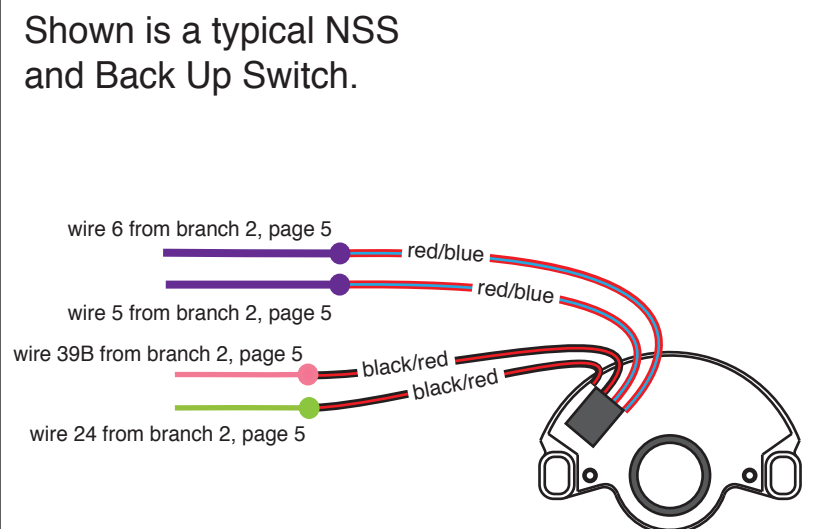

Figure "D"



www.americanautowire.com 856-933-0801

PART # **510386**
DESCRIPTION:
1965 Ford Falcon
Classic Update Series Kit
92970579 Rev. 4.0 1/23/2018

FUSE AND FLASHER LOCATIONS

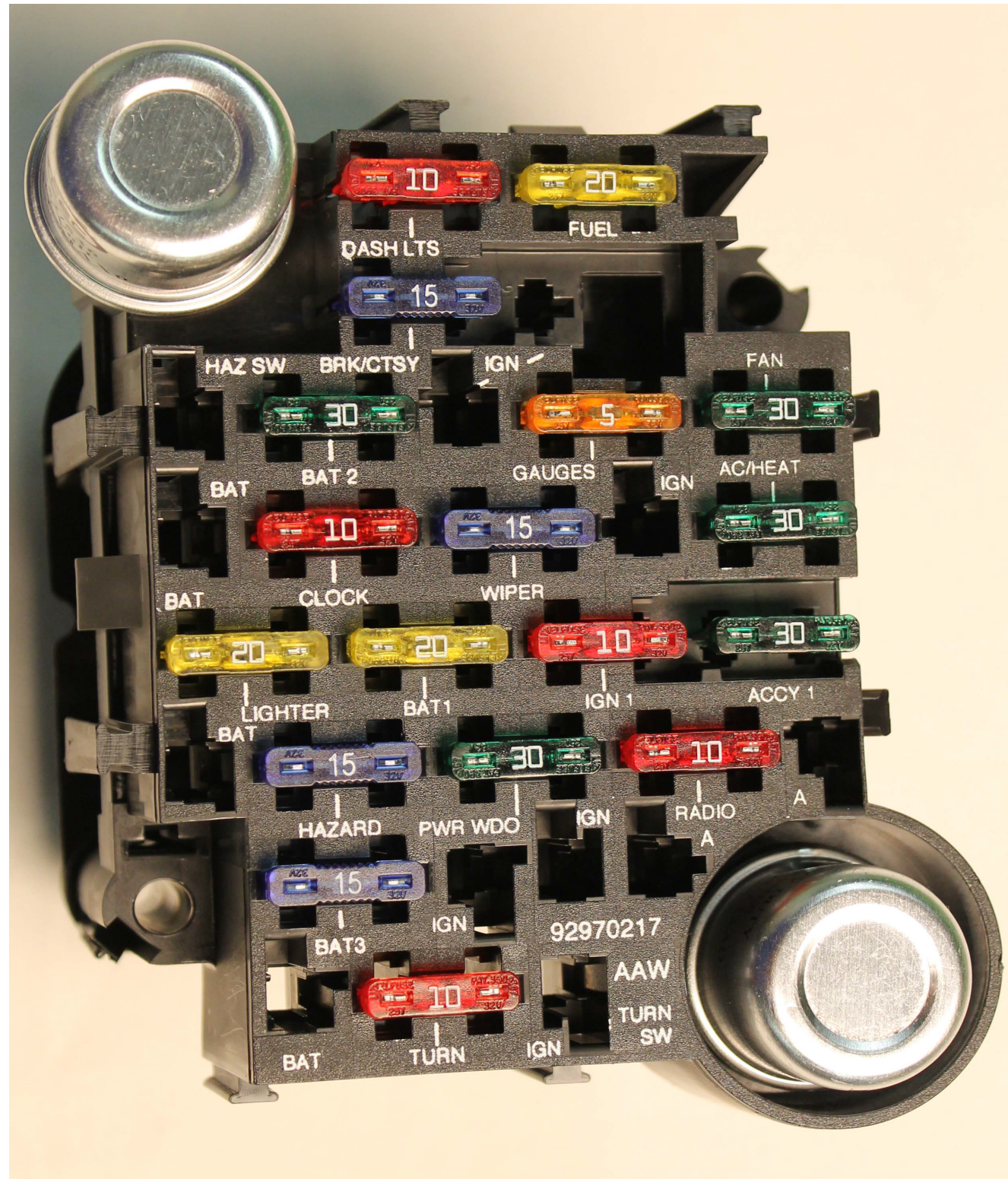

NOTE: Above, you will find a photograph of the completed Fuse Block assembly depicting the proper location for the installation of each fuse and the two flasher cans.



www.americanautowire.com 856-933-0801

PART # **510386**

DESCRIPTION:

1965 Ford Falcon

Classic Update Series Kit

92970579 Rev. 4.0 1/23/2018